

Mark 3

# Mini Receiver



MHT Technology Ltd's Tank Gauging Hardware



**MHT Technology Ltd**  
Digital Transformation with Human Design

+44 1748 828820

[www.mht-technology.co.uk](http://www.mht-technology.co.uk)

[sales@mht-technology.co.uk](mailto:sales@mht-technology.co.uk)

The Mini Receiver consolidates devices from multiple vendors into a single unit for cost-effective bulk liquid storage.

Learn more about our scalable, open solution suitable for depots, terminals, and refineries.



79 Types of Instruments Supported



Trusted by customers for over 15 years



Up to 256 tanks



Supports up to 400 devices and 20 ports

## Overview

The Mini Receiver from MHT Technology is a small integrated tank gauging and tank inventory management system utilising the latest Windows 10 IoT embedded technology. The Mini Receiver consolidates devices from multiple vendors into a single unit for cost-effective bulk liquid storage. Learn more about our scalable, open solution suitable for depots, terminals, and refineries. The Mini Receiver is designed to keep our customer's site's running as efficient and cost-effective as possible.

It is a smartly compact tank gauging and tank inventory management system, suited for tank farms of any size using various communication protocols for their installed field devices. MHT's Mini Receiver 'mark 1' was first launched in 2006, revolutionising the industry by enabling sites to have more freedom in their suppliers and eliminating 'vendor lockin.' Since then we have continued to innovate by developing the latest version 'the mark 3' in 2013 which directly interfaces up to 400 devices simultaneously. Should a site's tank gauging system be unable to display tank gauging information then the Mini Receiver screen allows some control over the site.

The Mini Receiver comes with support for 4, 12 and 20 ports that can serve as host or field ports, full inventory calculations to API/ASTM standards, an OPC Data Access Server and much more. It features a full graphical 7" LCD display with touch screen technology showing live and calculated tank data allowing control over the field instrumentation as well as alarm and events notification.

In addition to being a small tank inventory management system, it can be used as a foreign device gateway to higher-level DCS and site-wide business information systems by emulating older proprietary protocols, as well as flexible protocols such as Modbus and OPC DA.



+44 1748 828820



[www.mht-technology.co.uk](http://www.mht-technology.co.uk)



[sales@mht-technology.co.uk](mailto:sales@mht-technology.co.uk)

# Key Features



## Different gauge commands

The display can also be used to invoke a range of gauge commands which include Servo Check / Test, Stow / Lock, Unstow / Unlock, Water Dip and Density /Temperature Profile.



## Networking functionality

The 20 port Mini features dual Ethernet ports, allowing redundancy at the network level with an autosensing connection which can be configured for different IP addresses.



## Configurability

Data can be displayed on an innovative 7" touch screen display that is customisable to suit individual site requirements and configure audible alarms.



## Reliability

All firmware is stored on a flash drive for maximum reliability, and integrated tools used to create custom configurations that suit individual site requirements are included as standard with each Mini Receiver.



## Service monitoring

An internal watchdog can be enabled to monitor the operation of critical services and should any fail, the system can be configured to automatically restart, ensuring maximum up-time.



## Flexibility

Vendors' device configuration tools such as Endress+Hauser DeviceCare, and Honeywell Enraf Ensite can be connected through the Mini Receiver using a technology called 'tunnelling' to allow instrument technicians to administer and maintain their fleet of gauges with the minimum of disruption.



## Communication options

Devices come equipped with 4, 12, or 20 communication ports, which can be equipped with proprietary field interfaces such as Honeywell Enraf BPM, Emerson TRL/2, or Endress + Hauser V1 and generic field interfaces such as RS422/RS485, RS232, Current Loop, and HART.



## Compatibility

The Mini Receiver can also be used as a foreign device gateway to higher-level DCS and site-wide business information systems by providing an open interface to older legacy and proprietary protocols and interfaces.



# System Architecture

The Mini can be supplied as a standalone unit or as a redundant pair. All models support a fully redundant architecture. If two identically configured Mini Receivers are booted up, one will automatically become active. The active Mini Receiver will poll for data whilst the passive one polls the active device for data. If communication is lost, the passive Mini Receiver will automatically take over.

- Standalone station
- Client-Server system
- Distributed multi-site systems
- Modbus and OPC interfaces to sitewide distributed control systems and other business systems
- Fieldbus and device-independent

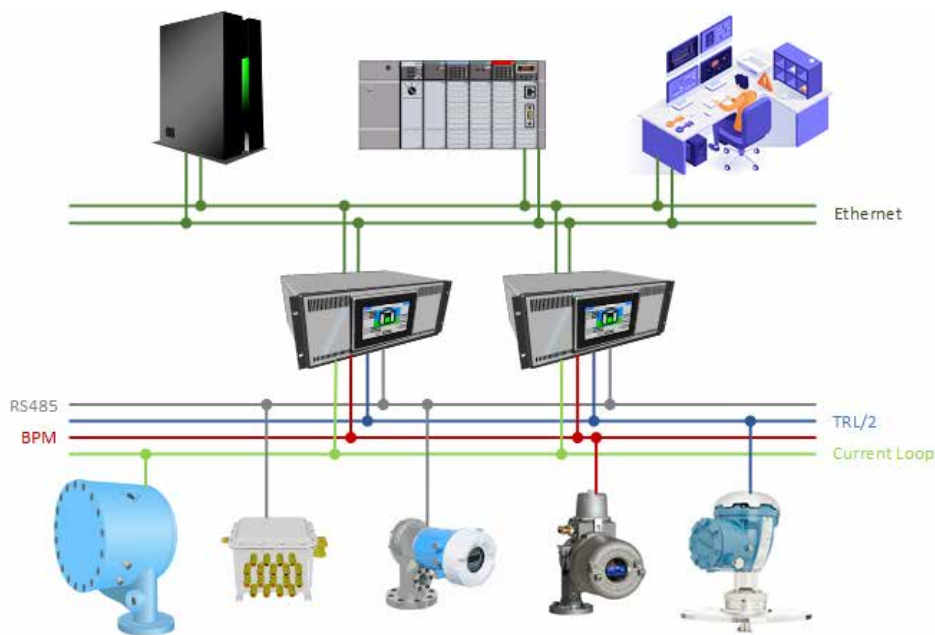

The Mini Receiver has 2 Ethernet ports, which can be configured to support redundant Ethernet or as separate networks. Devices in a redundant configuration may either use one of these ports to synchronise themselves, or a pair of serial ports. The performance of the Mini Receiver can be monitored via a built in SNMP interface allowing access to statistics such as the number of communication faults on a field bus, when and why redundant switchovers have occurred

## The requested gauge commands can be invoked from the display:-

- Stow/Lock
- Unstow/Unlock
- Water Dip

NOTE: this is provided that the gauges support the above commands.

A long list of inventory calculation methods is supported complying with all of the common API/ASTM methods. A full detailed list can be provided.

## Key Features

- Windows 10 IoT embedded system
- Full-colour graphical LCD Interface with Touch Screen
- Inventory calculations to API/ASTM Standards
- Available with 4, 12 or 20 communication ports configurable as host or field interfaces
- Dual Ethernet port
- Field interfaces for most makes of tank gauge
- Up to 256 tanks

The device is provided with a set of configuration tools that allow custom configurations to be created to suit individual site requirements.

## External dimensions:

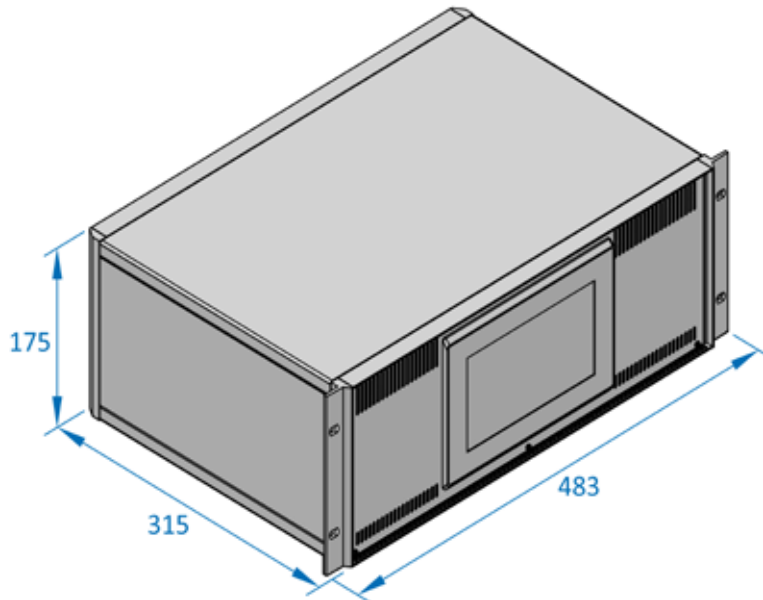

## Protocols on the interfaces:

- GPU
- Modbus Server
- Modbus Client
- Whessmatic 550
- Whessmatic 660
- V1
- Varec
- L&J

## Electrical interfaces are:

- BPM
- TRL/2
- RS485/RS232
- Current Loop
- V1
- Varec Mark Space

## Technical Specifications:

<b>CPU:</b>	Intel Celeron 1.58Ghz
<b>Memory:</b>	4 GB RAM
<b>Storage:</b>	8 GB SSD
<b>Operating System:</b>	Windows 10 IoT
<b>Optional Display:</b>	7" widescreen module (640 x 480 px)
<b>Input:</b>	Touch screen
<b>Serial Comms:</b>	RS-232, RS-422, RS-485, Honeywell BPM, Emerson TRL/2, Current Loop, L&J Tankway, Varec Mark Space, Endress+Hauser V1, Hectronic, HART
<b>Client Protocols:</b>	Honeywell GPU, Modbus (Emerson, SI, E+H, and generic), L&J, Hectronic, Varec, Motherwell, Modbus RTU, L&J tankway, Contrec SLIP
<b>Host Protocols:</b>	Modbus (including emulation of CIU880 Prime), Modbus/TCP, OPC DA, Enraf ASCII
<b>Weight:</b>	4.5 - 6.0 kg

<b>Ethernet:</b>	2 ports, 10/100 Mbps, auto sensing
<b>Power supply:</b>	100-240 VAC
<b>Power consumption:</b>	70W (3.5 @ 230V)
<b>USB:</b>	2 external ports, USB2.0 Type-A
<b>Comms status:</b>	Tx/Rx LEDs for individual ports
<b>IP rating:</b>	IP20
<b>Operating temperature:</b>	0 to 40 °C
<b>Storage temperature:</b>	0 to 85 °C
<b>Mounting:</b>	19" rack, 4U
<b>Host interface support:</b>	Modbus TCP via Ethernet, Modbus RTU Client, OPC Data Access Server, Enraf ASCII Host, Whessoe ASCII Host, 'Saab' TankMaster.